



CLARK PACIFIC

1980 SOUTH RIVER ROAD
W SACRAMENTO, CA 95691
TEL: (916) 371-0305
FAX: (916) 372-0323

13592 SLOVER AVENUE
FONTANA, CA 92337
TEL: (909) 823-1433
FAX: (909) 823-1361

PROJECT

JOB

CONTRACTOR

SHEET

DT/DT CONN. DETAIL

DATE 1-6-04

BY DW/BH CHECK

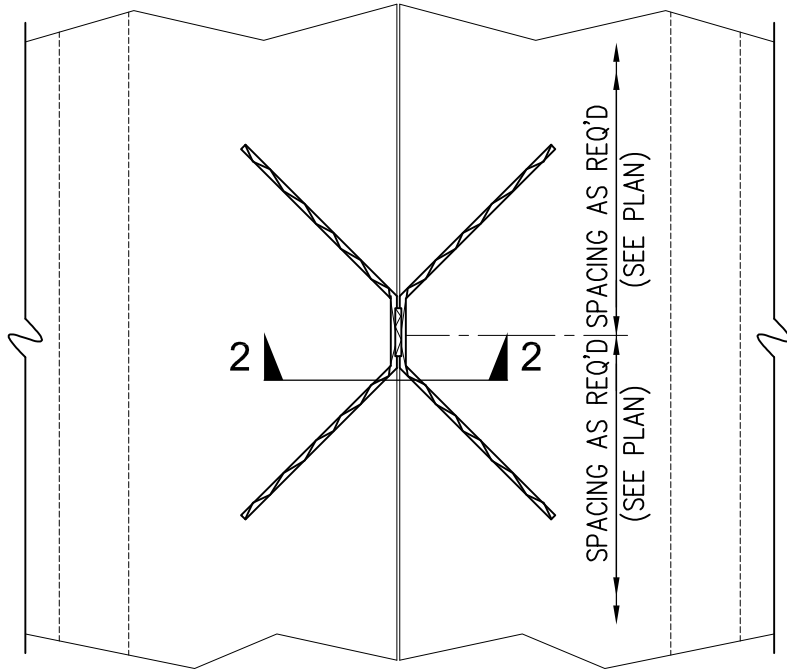

1 PLAN
SCALE: 3/4" = 1'-0"

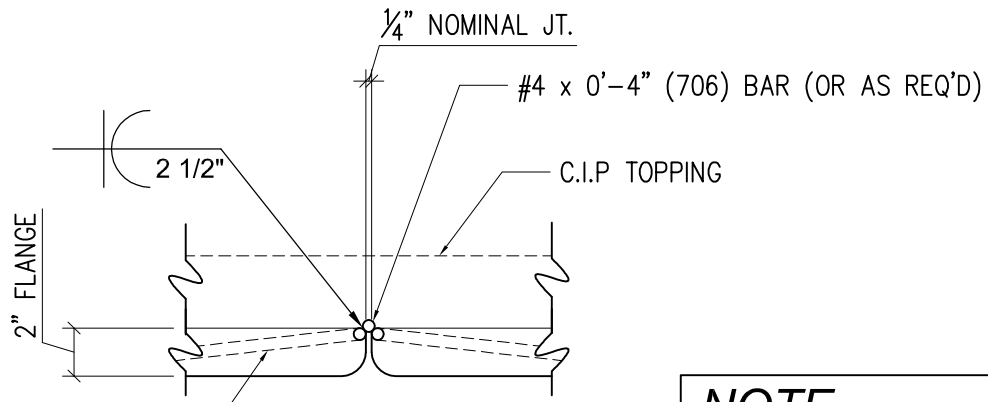

#4 (A706)
1'-6" 6" 1'-6"
(TYP.) SEE PLAN FOR SPA.

2 SECTION
SCALE: 1 1/2" = 1'-0"

NOTE
CONNECTION SHOWN
IS FOR ERECTION
PURPOSES ONLY!